

Technical Data

Alluna Ritchey-Chrétien telescopes

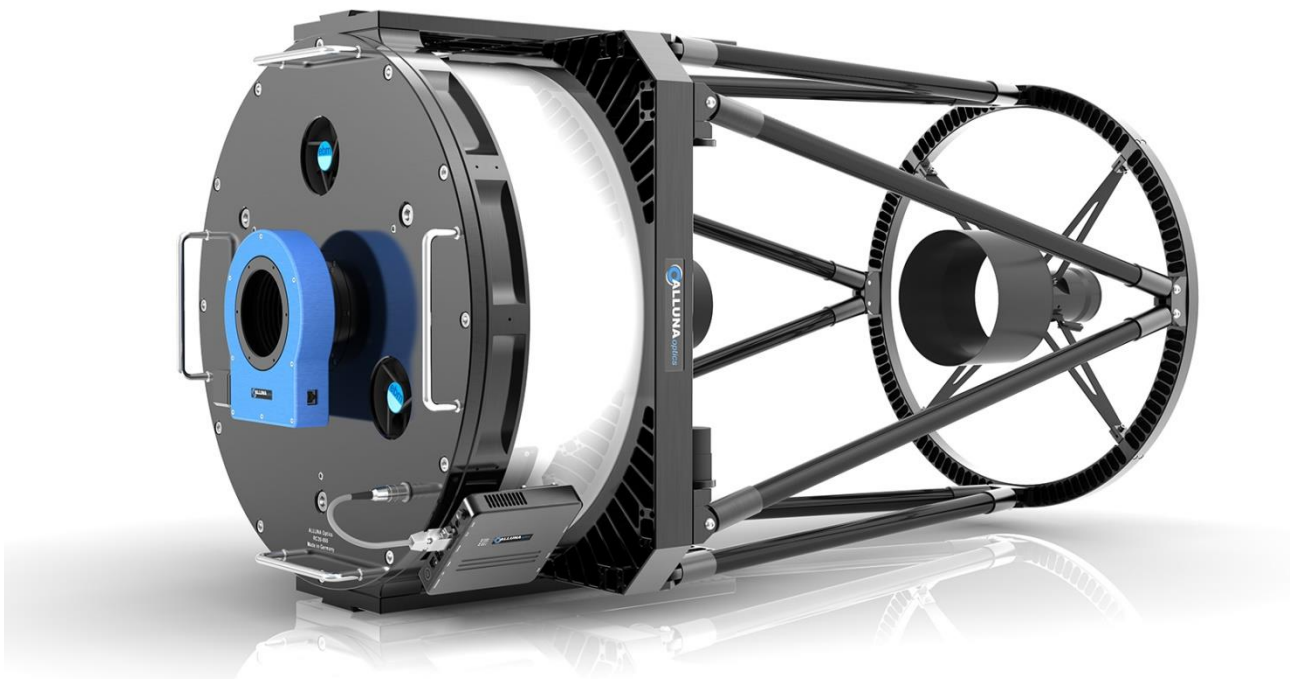

Alluna Optics, Dr.-Jaufmann-Strasse 18, Germany 86399 Bobingen,
eMail: info@alluna-optics.de , Web: www.alluna-optics.com

Alluna *optics* Ritchey-Chrétien Telescopes are professional telescopes of high “Made in Germany” quality. Ideal for observatories, schools, education, research and in particular for astrophotography.

The telescopes are available in standard sizes 16“, 18“, 20“, 22“ & 24 inches.



All telescopes can be used as a f/8,0 system or with a reducer as a f/6,0 system.

For highly accurate precision optics, optionally made of Zerodur glass ceramic, only optics exclusively of our manufacturing are used. It is only in this way that we can guarantee a consistently high quality of all our telescope optics.

The aluminium carbon truss tube, an elaborate honeycomb structure, is manufactured from solid aluminium. With this, an extremely high stability, torsion resistance and collimation is achieved. Instrument loads of greater than 50 kg can be implemented.

The integrated Telescope-Control-System (TCS2) controls all the basic functions of the main telescope:

- High precision secondary mirror focusing of the optic. Focus accuracy 0,0019 mm.
- Cooling of the optical tube. Three fans, real-time temperature query of the main mirror, secondary mirror and ambience.
- Control of the DustCover
Four-fold flaps, opening time 6-12 seconds depending on the telescope size
- Instrument rotator
Positional accuracy 0,01 degree
Maximum speed of approximately 4,9 °/sec
- Mirror heater
- Ascom connection

The control can be carried out via Notebook/PC, autonomously via the touch screen hand controller or remotely.

With the “Application Programming Interface” contained in the delivery, you can integrate the functionality into your own applications.

More information about our telescopes at: www.alluna-optics.com

Technical Data Alluna Ritchey-Chrétien telescopes:

	RC16	RC18	RC20	RC22	RC24
Primary mirror Ø	415 mm	465 mm	515 mm	562 mm	612 mm
Optical Ø	405 mm	455 mm	505 mm	550 mm	600 mm
Main mirror ap.	f/3,0	f/3,0	f/3,0	f/3,0	f/3,0
System ap.	f/8,0	f/8,0	f/8,0	f/8,0	f/8,0
Secondary mirror Ø	160 mm	175 mm	190 mm	205 mm	222 mm
Obstruktion	43%	43%	42%	41%	41%
Back Focus / mirror	355 mm	355 mm	355 mm	355 mm	355 mm
Back Focus / backplate	250 mm	245 mm	240 mm	235 mm	230 mm
Weight	49 kg	62 kg	79 kg	95 kg	110 kg
Telescope-Control-System TCS	TCS-2 including	TCS-2 including	TCS-2 including	TCS-2 including	TCS-2 including
TCS Windows Software	✓	✓	✓	✓	✓
API - Application Programming Interface	✓	✓	✓	✓	✓
Hand-Control Panel*	✓	✓	✓	✓	✓
4" RC Field Corrector* f/8,0 to f/8,1	✓	✓	✓	✓	✓
4" RC Reducer .74x* f/8,0 to f/6,0	✓	✓	✓	✓	✓
4" Instrument Rotator*	✓	✓	✓	✓	✓
Robotic DustCover*	✓	✓	✓	✓	✓

*optional

16" Alluna Carbon-Truss-RC

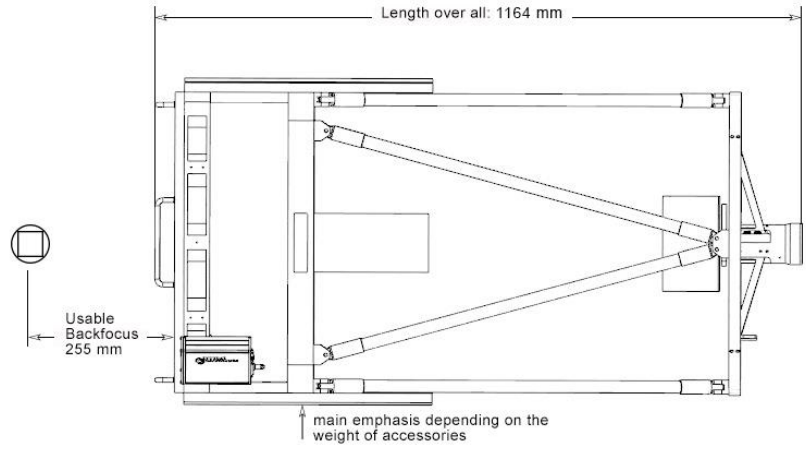
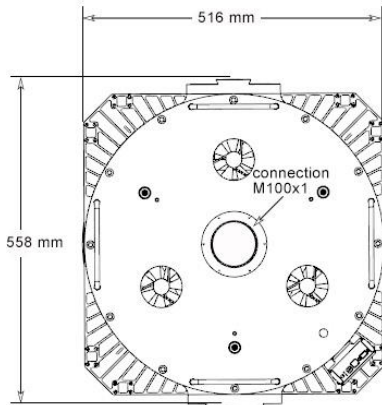

18" Alluna Carbon-Truss-RC

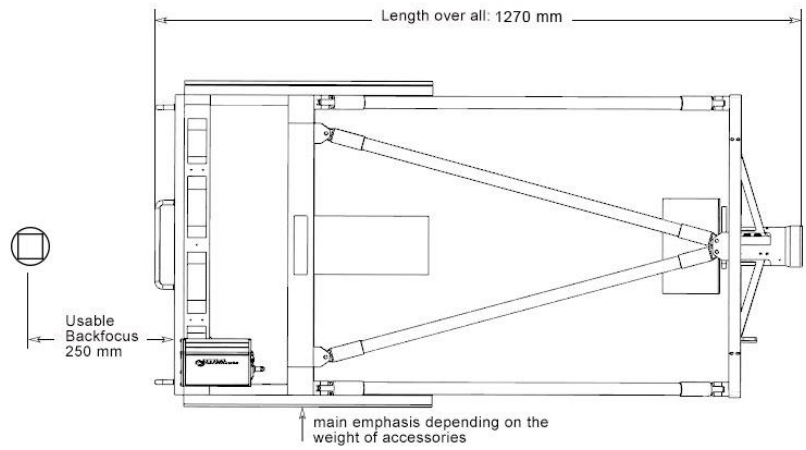
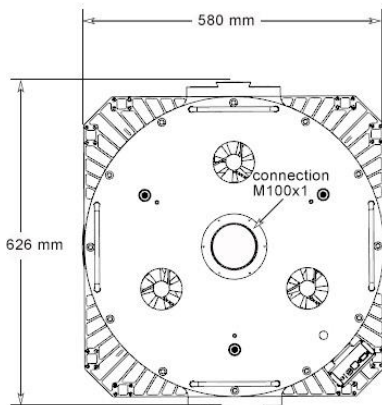

20" Alluna Carbon-Truss-RC

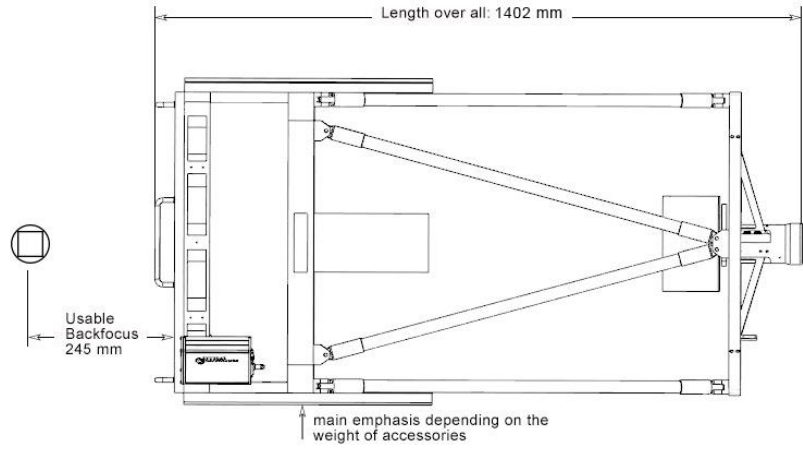
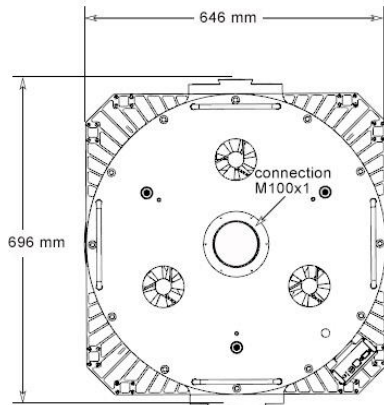

22" Alluna Carbon-Truss-RC

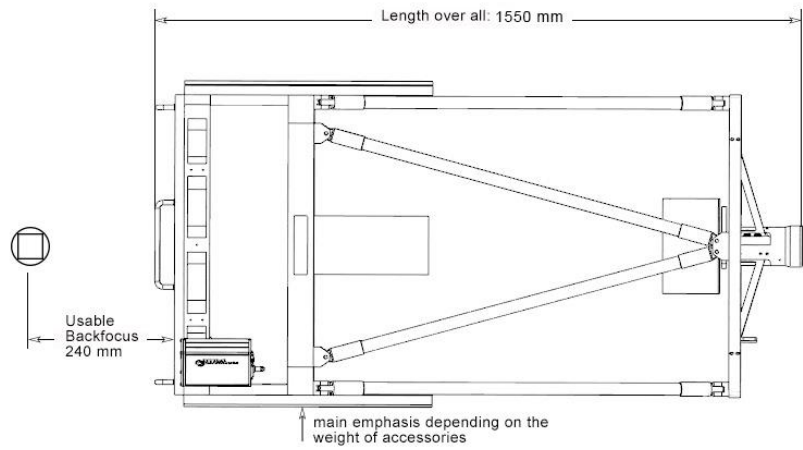
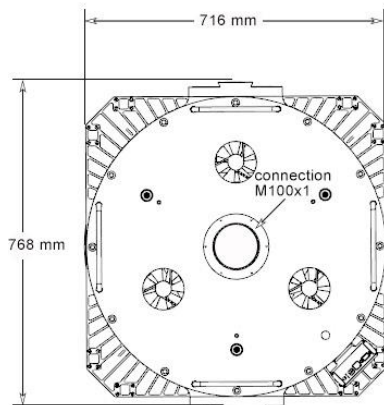

24" Alluna Carbon-Truss-RC

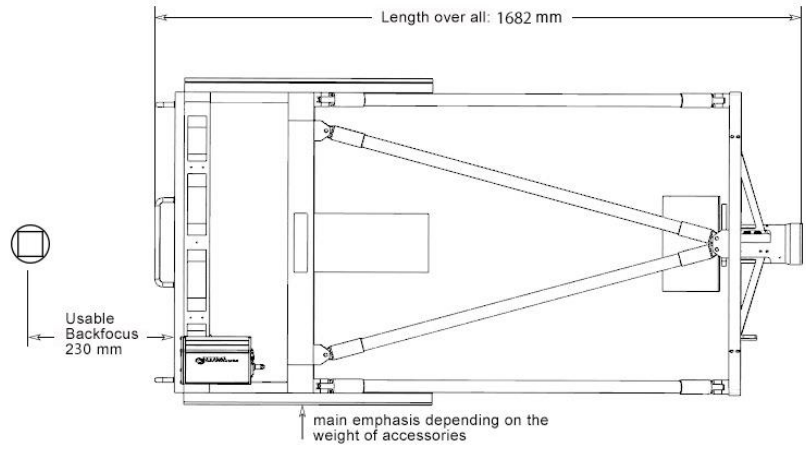
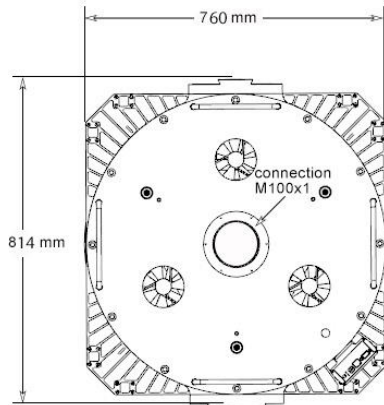

We reserve the right at any time to deviations from specifications or changes as well as printing errors on these pages.

an example installation RC20 on Paramount mount

